

ABOVE COUNTER BASIN

Q50H1

Slimline Above Counter Basin

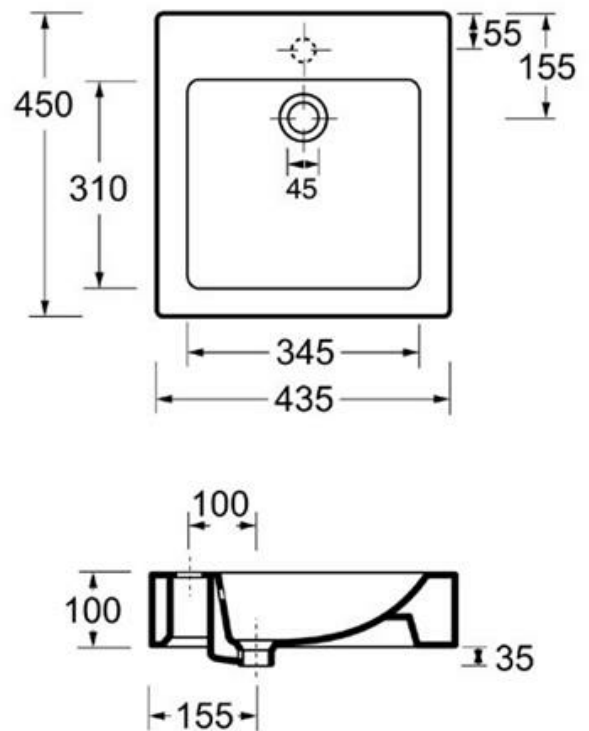

AQUA CONCEPTS

10/46 SMITH ST, SOUTHPORT, QLD 4215 PH: 07 5503 0855 FAX: 07 5503 0877

SPECIALISED PROJECT SERVICES

216/354 EASTERN VALLEY WAY, CHATSWOOD EAST, NSW, 2067

PH: 02 9417 0599 FAX: 02 9417 0755